

K&K Audio

RAKK dac

Mark III

Raleigh Audio

I2S Interface Adapter

Interface Specification and Installation Manual

Kit version

Use this manual with:

- RAKK Remote I2S Adapter, v 1.0, which is marked on the boards.

Required Tools and Supplies

35 to 50 Watt soldering iron

Diagonal cutting pliers

Long-nose pliers

Wire stripper

Solder

Warnings and Cautions

Caution – Use only solder that is intended for electrical circuits. Do not use acid or corrosive flux of any kind.

Support

RAKK dac and its associated components are produced through the joint cooperation of K&K Audio and Raleigh Audio. You may contact us with questions on constructing this kit by sending an e-mail message to david@raleighaudio.com or kevin@kandkaudio.com

Table of Contents

Preface	3
Introduction	4
Implementation Instructions	5
PS Audio PWT Attachment	5
Generic CD Transport Attachment	5
I2S Interface Adapter Receive Board Installation Instructions	6
I2S Interface Adapter Send Board Installation Instructions	7
I2S Interface Adapter Receive Board Interface Specifications	8
Internal I2S interface	8
External I2S interface	8
Power Supply input	8
I2S Interface Adapter Send Board Interface Specifications	9
Internal I2S interface	9
External I2S interface	9
Power Supply input	9
Isolation	10
Document version history	10

Preface

For a digital interface to be defined, three aspects must be described: the logical, the electrical and the mechanical. The logical description tells how the data are encoded – for example, the number of signal and clock lines and how they relate. The electrical description outlines the structure – single ended or balanced – and the voltage, current and impedance of the circuit. The mechanical description covers the type of connector (if any) and how its pins are used.

The design of an interface is determined by the purpose of the interface; the Inter-IC Sound (I2S) interface was developed by Phillips for streaming digital audio between devices. As the name implies, a device was originally thought to be an Integrated Circuit (IC), usually on the same circuit board or between two boards in the same enclosure. Being an internal¹ interface, the number of lines used by the interface is not as critical as it is with an interface intended for communicating externally between two enclosures. Therefore three lines (one data and two clocks) were chosen for encoding the data. Because it is an internal interface, the ubiquitous TTL electrical specifications were chosen for the interface. Again, because it is an internal interface, there was no need to specify an external connector, so there is no mechanical definition.

For communicating externally between two enclosures, Phillips collaborated with Sony to develop the S/PDIF interface, which has a very different logical, electrical and mechanical specification from that of the I2S interface. Most significantly, since the numbers of lines are critical for an external interface, the data and timing are encoded onto a single line. Unfortunately, there is a trade-off to be made between the number of lines used by the interface and the jitter performance of the interface.

The superior performance of the I2S interface has enticed engineers to develop schemes to extend the function of the I2S interface so that it may be used externally between two enclosures. It is important to realize that there are no extensions to the Phillips I2S standard defined for external communication. All external I2S interfaces are proprietary ad-hoc solutions developed by companies for their own use and are different from each other.

To optimize the I2S interface for external communication between two enclosures, two aspects – the electrical and the mechanical – must be addressed. The electrical interface must be addressed because TTL technology demonstrates its best performance over very short distances within a single enclosure. Other technologies are typically used when a connection to an external device is needed. The mechanical aspect must be addressed simply because there is no I2S mechanical definition.

¹ For this document, “internal” means inside or within an enclosure or chassis; conversely, “external” means outside an enclosure or chassis.

Introduction

The I2S Interface Adapter provides the capability to attach a component, such as a CD transport, to the RAK dac Mark III using an external I2S interface. The adapter consists of circuitry to convert internal TTL level signals to external differential signals and vice versa.

The adapter consists of two PC boards: a send board and a receive board. The send board resides in the CD transport and converts its internal TTL signals to external differential signals. The receive board resides in the RAKK dac Mark III enclosure and converts the external differential signals to internal TTL signals used by the RAKK dac. The two boards are provided completely assembled, ready for installation.

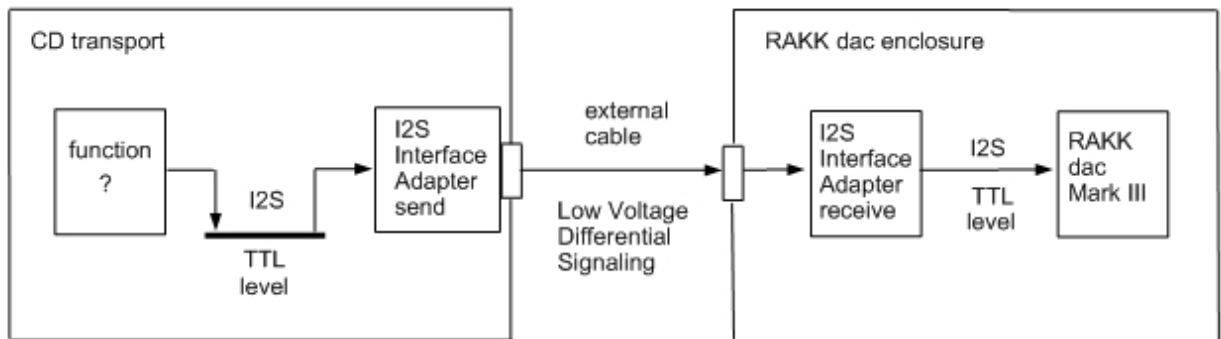

The circuitry in the CD transport could be anything and we have no way of knowing about it. Therefore it is up to you to determine how to connect the send board to the I2S signals in that device. Because of this, we strongly recommend that the send board be used only by someone who has the necessary knowledge and skills to undertake the project without guidance.

There are several appropriate technologies for external digital interfaces. We found that the engineers at PS Audio had chosen Low Voltage Differential Signaling (LVDS) as the technology for interconnecting their superb PerfectWave products. It made sense for us to follow suit and use the interface that PS Audio had defined, including HDMI physical cables. By doing so we can directly attach the PS Audio PerfectWave Transport (PWT) to the RAKK dac Mark III via the receive board. In this case, the send board is not used and no change of any kind is made to the PWT.

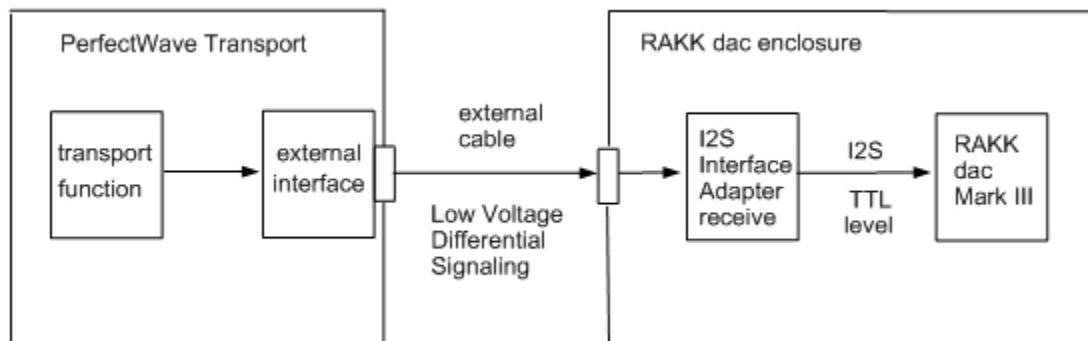

Implementation Instructions

PS Audio PWT Attachment

- Follow the receive board installation instructions below.
- Connect the PWT to the RAKK dac enclosure using a standard HDMI cable.

Generic CD Transport Attachment

- Follow the receive board installation instructions below.
- Follow the send board installation instructions below.
- Connect the CD transport to the RAKK dac enclosure using a standard HDMI cable.

I2S Interface Adapter Receive Board Installation Instructions

The receive board is designed to be mounted to the RAKK dac Mark III board. These instructions assume that the receive board will be used with the RAKK dac Mark III.

1. Complete the assembly of the RAKK dac Mark III.

 2. Mount the receive board on the RAKK dac such that the I2S interface pads are co-located. Use four standoffs and screws.

 3. Install six short wires between the I2S interface pads on the two boards. Observe polarity—the pads are aligned and labeled.

 4. Mount the two boards in their location and secure them in place.

 5. Install the internal HDMI cable, if used.

 6. Install a twisted pair of wires from the 12V pads on the receive board to the 12V power supply. Observe polarity. If you use the RAKK dac Mark III LVPS, refer to its manual for instructions.

 7. If you have an LED indicator that will show that a device is attached, connect the wires from it to the **“attached”** LED pads on the receive board. Observe polarity: the LED cathode should go to the “C” pad and the LED anode should go to the “A” pad. LED polarity can be confusing: If the LED does not light, switch the “A” and “C” leads.
-

Note that the LED intensity is controlled by the adjustable resistor R1.

I2S Interface Adapter Send Board Installation Instructions

The send board is designed to be mounted with a screw on the HDMI connector through the back panel on the CD transport.

1. Cut a hole in the back panel large enough to accept the HDMI connector. Drill a small screw hole above the connector hole.
-

2. Mount the send board on the back panel and secure it in place with a screw.
-

3. Locate the internal TTL level I2S buss and determine an appropriate place to pick up the three signals. Install a wire for each of the signals, SD, BCK and LRCK, to the labeled pads on the send board.
-

4. Install a twisted pair of wires from the +5V and Ground pads on the send board to the 5V power supply. Observe polarity.
-

I2S Interface Adapter Receive Board Interface Specifications

Internal I2S interface

The I2S interface is galvanically isolated from the circuitry and ground on the RAKK dac board. Therefore all six wires must be connected for proper operation. The interface is implemented with a standard 3.3V logic family and is designed to operate into standard 3.3V or 5V logic families.

Electrical definition:

Nominal output pulse amplitude = 3.0V

Absolute minimum load impedance = 200Ω

External I2S interface

Electrical definition: The electrical interface is defined by the National Semiconductor [DS090LV032](#) LVDS differential Line Receiver.

Mechanical definition: The interface uses the following pins on a standard HDMI connector:

- Pin 1: Send Data (SD) –
- Pin 3: Send Data (SD) +
- Pin 4: Bit Clock (BCK) +
- Pin 6: Bit Clock (BCK) –
- Pin 7: Word Clock (LRCK) –
- Pin 9: Word Clock (LRCK) +
- Pin 17: Ground
- Pin 19: Attached –

Power Supply input

The receive board requires +12V at 75mA. The input voltage is isolated from the on-board regulators by a DC-DC convertor. This, together with the isolated I2S interface on the RAKK dac Mark III provides complete galvanic isolation between the RAKK dac and the attaching device.

I2S Interface Adapter Send Board Interface Specifications

Internal I2S interface

The I2S signals are referenced to power ground. The interface is implemented with a standard 3.3V logic family and is designed to operate with standard 3.3V or 5V logic families.

External I2S interface

Electrical definition: The electrical interface is defined by the National Semiconductor [DS090LV031](#) LVDS differential Line Driver.

Mechanical definition: The interface uses the following pins on a standard HDMI connector:

Pin 1: Send Data (SD) –
Pin 2: Shield
Pin 3: Send Data (SD) +
Pin 4: Bit Clock (BCK) +
Pin 5: Shield
Pin 6: Bit Clock (BCK) –
Pin 7: Word Clock (LRCK) –
Pin 8: Shield
Pin 9: Word Clock (LRCK) +
Pin 17: Ground
Pin 19: Ground

- The Shields on pins 2, 5 and 8 are connected to ground.
- The Ground on pin 17 is connected to the power ground of the housing component. This Ground, carried through the cable, provides the ground reference for the receive board.
- The Ground on pin 19 provides the “attached” condition in the receive board.

Power Supply input

The send board requires +5V at 20mA.

Isolation

For the best performance, ground loops must be eliminated; therefore great care has been taken to galvanically isolate the ground on the external interface from the ground in the RAKK dac enclosure. There are two potential problem areas – the power supply interface and the signal interface.

For the signal interface, we have chosen to provide a galvanically isolated I2S interface (both signal and ground) on the RAK dac Mark III.

For the power supply interface, the receive board has a galvanically isolated DC-DC power supply.

Document version history

Version	Description
1.0	Original document