

**K&K Audio**

# **RAKK dac**

## **Mark III**

**Raleigh Audio**

# **I2S Interface Adapter**

## **Interface Specification and Installation Manual**

## Kit version

Use this manual with RAKK I2S Interface Adapter

- Board version 2 which is marked on the boards
- Parts level B

Note that the adapter was originally called “RAKK Remote I2S Adapter” and was changed to be “RAKK I2S Interface Adapter.”

## Required Tools and Supplies

35 to 50 Watt soldering iron

Diagonal cutting pliers

Long-nose pliers

Wire stripper

Solder

## Warnings and Cautions

**Caution** – Use only solder that is intended for electrical circuits. Do not use acid or corrosive flux of any kind.

## Support

RAKK dac and its associated components are produced through the joint cooperation of K&K Audio and Raleigh Audio. You may contact us with questions on constructing this kit by sending an e-mail message to [david@raleighaudio.com](mailto:david@raleighaudio.com) or [kevin@kandkaudio.com](mailto:kevin@kandkaudio.com)

## Table of Contents

Preface .....	3
Introduction .....	4
Implementation Instructions .....	5
PS Audio PWT Attachment .....	5
Generic CD Transport Attachment .....	5
Isolation .....	5
I2S Interface Adapter Receive Board Assembly Instructions .....	6
I2S Interface Adapter Receive Board Installation Instructions .....	8
I2S Interface Adapter Send Board Installation Instructions .....	9
I2S Interface Adapter Receive Board Interface Specifications .....	10
Internal I2S interface .....	10
External I2S interface .....	10
Power Supply input .....	10
I2S Interface Adapter Send Board Interface Specifications .....	11
Internal I2S interface .....	11
External I2S interface .....	11
Power Supply input .....	11
Parts List (Level B) .....	12
Document version history .....	13
Parts Level History .....	13

## Preface

For a digital interface to be defined, three aspects must be described: the logical, the electrical and the mechanical. The logical description tells how the data are encoded – for example, the number of signal and clock lines and how they relate. The electrical description outlines the structure – single ended or balanced – and the voltage, current and impedance of the circuit. The mechanical description covers the type of connector (if any) and how its pins are used.

The design of an interface is determined by the purpose of the interface; the Inter-IC Sound (I2S) interface was developed by Phillips for streaming digital audio between devices. As the name implies, a device was originally thought to be an Integrated Circuit (IC), usually on the same circuit board or between two boards in the same enclosure. Being an internal<sup>1</sup> interface, the number of lines used by the interface is not as critical as it is with an interface intended for communicating externally between two enclosures. Therefore three lines (one data and two clocks) were chosen for encoding the data. Because it is an internal interface, the ubiquitous TTL electrical specifications were chosen for the interface. Again, because it is an internal interface, there was no need to specify an external connector, so there is no mechanical definition.

For communicating externally between two enclosures, Phillips collaborated with Sony to develop the S/PDIF interface, which has a very different logical, electrical and mechanical specification from that of the I2S interface. Most significantly, since the numbers of lines are critical for an external interface, the data and timing are encoded onto a single line. Unfortunately, there is a trade-off to be made between the number of lines used by the interface and the jitter performance of the interface.

The superior performance of the I2S interface has enticed engineers to develop schemes to extend the function of the I2S interface so that it may be used externally between two enclosures. It is important to realize that there are no extensions to the Phillips I2S standard defined for external communication. All external I2S interfaces are proprietary ad-hoc solutions developed by companies for their own use and are different from each other.

To optimize the I2S interface for external communication between two enclosures, two aspects – the electrical and the mechanical – must be addressed. The electrical interface must be addressed because TTL technology demonstrates its best performance over very short distances within a single enclosure. Other technologies are typically used when a connection to an external device is needed. The mechanical aspect must be addressed simply because there is no I2S mechanical definition.

---

<sup>1</sup> For this document, “internal” means inside or within an enclosure or chassis; conversely, “external” means outside an enclosure or chassis.

## Introduction

The I2S Interface Adapter provides the capability to attach a component, such as a CD transport, to the RAK dac Mark III using an external I2S interface. The adapter consists of circuitry to convert internal TTL level signals to external differential signals and vice versa.

The adapter consists of two PC boards: a send board and a receive board. The send board resides in the CD transport and converts its internal TTL signals to external differential signals. The receive board resides in the RAKK dac Mark III enclosure and converts the external differential signals to internal TTL signals used by the RAKK dac. The two boards are provided completely assembled, ready for installation.

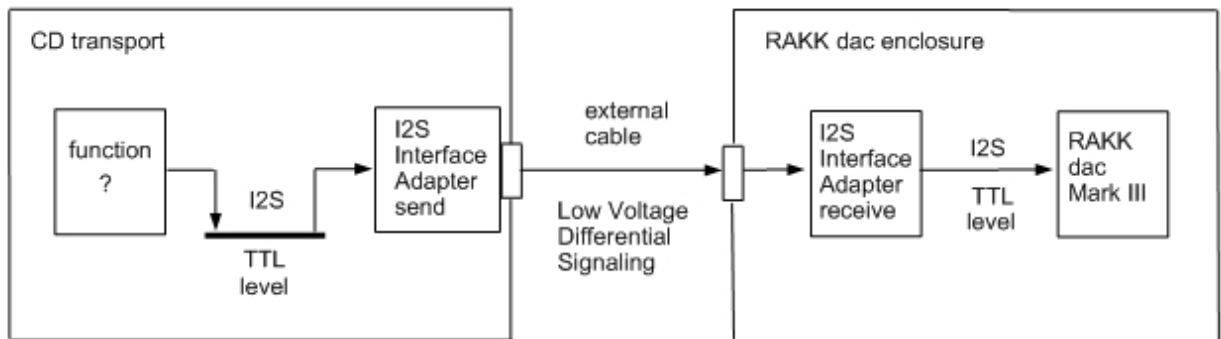

The circuitry in the CD transport could be anything and we have no way of knowing about it. Therefore it is up to you to determine how to connect the send board to the I2S signals in that device. Because of this, we strongly recommend that the send board be used only by someone who has the necessary knowledge and skills to undertake the project without guidance.

There are several appropriate technologies for external digital interfaces. We found that the engineers at PS Audio had chosen Low Voltage Differential Signaling (LVDS) as the technology for interconnecting their superb PerfectWave products. It made sense for us to follow suit and use the interface that PS Audio had defined, including HDMI physical cables. By doing so we can directly attach the PS Audio PerfectWave Transport (PWT) to the RAKK dac Mark III via the receive board. In this case, the send board is not used and no change of any kind is made to the PWT.

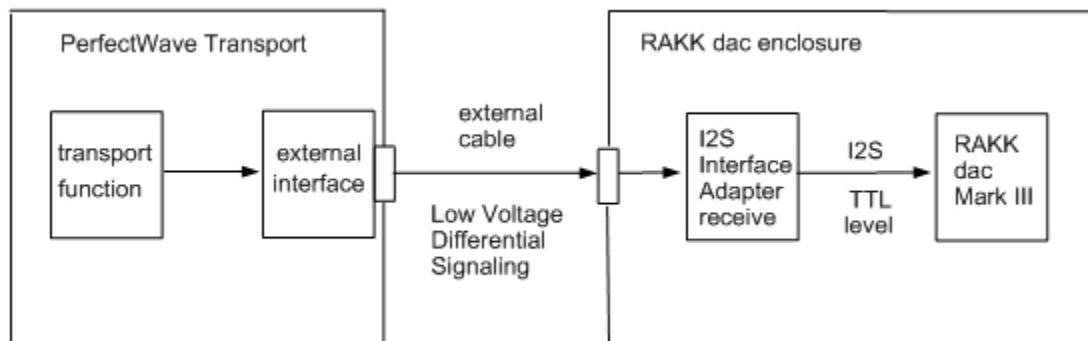

## Implementation Instructions

### PS Audio PWT Attachment

- Refer to the Assembly section below and install the power isolation parts if needed.
- Follow the receive board installation instructions below.
- Connect the PWT to the RAKK dac enclosure using a standard HDMI cable.

### Generic CD Transport Attachment

- Refer to the Assembly section below and install the power isolation parts if needed.
- Follow the receive board installation instructions below.
- Follow the send board installation instructions below.
- Connect the CD transport to the RAKK dac enclosure using a standard HDMI cable.

## Isolation

For the best performance, ground loops must be eliminated; therefore great care must be taken to galvanically isolate the ground on the external interface from the ground in the RAKK dac enclosure. There are two potential problem areas – the power supply interface and the signal interface.

For the signal interface, we have chosen to provide a galvanically isolated I2S interface (both signal and ground) on the RAK dac Mark III.

The receive board does not have a galvanically isolated power supply interface. Rather, the preferred solution is to provide a totally separate DC power supply. This means a power supply derived from a separate power transformer or a separate (non-shared) winding on a power transformer. The RAKK dac Mark III version 2 Low Voltage Power System provides separate power supplies for the RAKK dac and the I2S Interface Adapter.

However, if a single supply is used for both the RAKK dac and I2S Interface Adapter, a power isolation circuit must be used. The traces for this circuit are provided on the I2S Interface Adapter board and a parts kit may be ordered separately. This isolation circuit is not needed, and should not be used if separate power supplies are used.

## I2S Interface Adapter Receive Board Assembly Instructions

---

1. Insert a 2K potentiometer in location R1.

Solder and trim the leads.

---

If you have separate power supplies for the RAKK dac and I2S Interface Adapter, skip the rest of this section and proceed to the next section. If the RAKK dac and I2S Interface Adapter share a single power supply, you will now install the optional isolation parts.

---

1. Insert a 22K (red, red, black, red, brown) resistor in location R13.

Solder and trim the leads.

---

2. Insert a 100K (brown, black, black, orange, brown) resistor in location R14.

Solder and trim the leads.

---

3. Insert a 1N4007 (marked on body) diode in location D1. Orient the diode such that the end of the diode without the stripe is closest to capacitor C24.

Solder and trim the leads.

---

4. Insert the LM555 timer in location U10. Orient the timer such that the end of the timer with a notch is closest to capacitor C22.

Solder the leads.

---

5. Insert the DCP021212 DC-DC converter module in location U6.

Solder the leads.

---

6. Insert a 0.1 $\mu$ F (tiny yellow) capacitor in each of the following two locations: C22 and C23.

Solder and trim the leads.

---

7. Insert the 1 $\mu$ F, 50V capacitor in location C24. Orient the capacitor such that the negative lead (marked on side) is closest to the edge of the board.

Solder and trim the leads.

---

8. Insert a relay in location K1.

Solder the leads.

---

9. Insert the 180 $\mu$ F, 16V capacitor in location C25. Orient the capacitor such that the negative lead (marked on side) is closest to the edge of the board.

Solder and trim the leads.

---

10. Connect a pair of wires between the “Output” pads of the 12V Power Isolation section and the “12V” pads on the I2S Interface Power Input.  
Observe polarity: + to + and – to –.

Solder the wires.

---

## I2S Interface Adapter Receive Board Installation Instructions

The receive board is designed to be mounted to the RAKK dac Mark III board. These instructions assume that the receive board will be used with the RAKK dac Mark III.

---

1. Complete the assembly of the RAKK dac Mark III.

---

2. Mount the receive board on the RAKK dac such that the I2S interface pads are co-located. Use four standoffs and screws.

---

3. Install six short wires between the I2S interface pads on the two boards. Observe polarity—the pads are aligned and labeled.

---

4. Mount the two boards in their location and secure them in place.

---

5. Install the internal HDMI cable, if used.

---

6. Install a twisted pair of wires from the 12V power supply to the 12V pads on the receive board (12V Power Isolation Input, if used). Observe polarity. If you use the RAKK dac Mark III LVPS, refer to its manual for instructions.

---

7. If you have an LED indicator that will show that a device is attached, connect the wires from it to the **“attached”** LED pads on the receive board. Observe polarity: the LED cathode should go to the “C” pad and the LED anode should go to the “A” pad. The longer lead on the LED is the anode.

---

Note that the LED intensity is controlled by the adjustable resistor R1.

---

## I2S Interface Adapter Send Board Installation Instructions

The Send board is designed to be mounted on the back panel on the CD transport with both a screw on the HDMI connector as well as brackets holding the board. The brackets have been pre-assembled on the board to show how it should be mounted.

---

1. Measure the board assembly with the brackets to determine a hole drilling pattern.
- 

2. Cut a hole in the back panel large enough to accept the HDMI connector.
- 

3. Drill three holes for the screws.
- 

4. Mount the Send board on the back panel and secure it in place with three screws.
- 

5. Locate the internal TTL level I2S buss and determine an appropriate place to pick up the three signals. Install a wire for each of the signals, SD, BCK and LRCK, to the labeled pads on the send board.
- 

6. Install a twisted pair of wires from the +5V and Ground pads on the send board to the 5V power supply. Observe polarity.
-

## I2S Interface Adapter Receive Board Interface Specifications

### Internal I2S interface

The I2S interface is galvanically isolated from the circuitry and ground on the RAKK dac board. Therefore all six wires must be connected for proper operation. The interface is implemented with a standard 3.3V logic family and is designed to operate into standard 3.3V or 5V logic families.

#### Electrical definition:

Nominal output pulse amplitude = 3.0V

Absolute minimum load impedance = 200Ω

### External I2S interface

**Electrical definition:** The electrical interface is defined by the National Semiconductor [DS090LV032](#) LVDS differential Line Receiver.

**Mechanical definition:** The interface uses the following pins on a standard HDMI connector:

- Pin 1: Send Data (SD) –
- Pin 3: Send Data (SD) +
- Pin 4: Bit Clock (BCK) +
- Pin 6: Bit Clock (BCK) –
- Pin 7: Word Clock (LRCK) –
- Pin 9: Word Clock (LRCK) +
- Pin 17: Ground
- Pin 19: Attached –

### Power Supply input

The receive board requires +12V at 20mA. For best performance, this power supply should be galvanically isolated from the RAKK dac 12V power supply. This, together with the isolated I2S interface on the RAKK dac Mark III will provide complete galvanic isolation between the RAKK dac and the attaching device.

## I2S Interface Adapter Send Board Interface Specifications

### Internal I2S interface

The I2S signals are referenced to power ground. The interface is implemented with a standard 3.3V logic family and is designed to operate with standard 3.3V or 5V logic families.

### External I2S interface

**Electrical definition:** The electrical interface is defined by the National Semiconductor [DS090LV031](#) LVDS differential Line Driver.

**Mechanical definition:** The interface uses the following pins on a standard HDMI connector:

Pin 1: Send Data (SD) –  
Pin 2: Shield  
Pin 3: Send Data (SD) +  
Pin 4: Bit Clock (BCK) +  
Pin 5: Shield  
Pin 6: Bit Clock (BCK) –  
Pin 7: Word Clock (LRCK) –  
Pin 8: Shield  
Pin 9: Word Clock (LRCK) +  
Pin 17: Ground  
Pin 19: Ground

- The Shields on pins 2, 5 and 8 are connected to ground.
- The Ground on pin 17 is connected to the power ground of the housing component. This Ground, carried through the cable, provides the ground reference for the receive board.
- The Ground on pin 19 provides the “attached” condition in the receive board.

### Power Supply input

The send board requires +5V at 20mA.

## Parts List (Level B)

Designator	Part	Description	Qty
R1	2K potentiometer	blue rectangle	1
	LED	green	1
	bracket with screws	mounted on Send board	2
	screw, 1 x 3mm	Send board connector mounting	1

Note that these parts are provided for the optional power isolation section.

Designator	Part	Description	Qty
	Schematic diagram	Diagram for the isolation section	1
R13	Resistor, 22K, ¼W metal film	Red, red, black, red, brown bands	1
R14	Resistor, 100K, ¼W metal film	Brown, black, black, orange, brown bands	1
D1	Diode, 1N4007	Black cylinder	1
C22, C23	Capacitor, 100nF, 50V	Tiny yellow	2
C24	Capacitor, 1µF, 50V	Dark blue cylinder	1
C25	Capacitor, 180µF, 16V	Dark blue cylinder	1
K1	Relay, DPDT	Black rectangle	1
U6	DC-DC convertor	14 pin DIP	1
U10	Timer, LM555	8 pin DIP	1

## Document version history

Document	Description
1.0	Original document Intended to support parts version 1
2.0	Intended to support parts version 2, level A
2.1	Document only update of power requirements. Include instructions for LED potentiometer.

## Parts Level History

Version	Level	Description
1		Original level
2	A	<ul style="list-style-type: none"><li>• Removed DC – DC convertor from receive board power supply</li><li>• Provided optional power isolation</li><li>• Added brackets to send board</li><li>• Cosmetic labeling changes</li></ul>
2	B	<ul style="list-style-type: none"><li>• Add 2K potentiometer</li></ul>